

RTQ120N080G2, RTW120N080G2, RTG120N080G2

1200V N-Channel Silicon Carbide Power MOSFET

1. Applications

Asymmetrical Bridge
 Converter
 Inverter
 Single Switch Forward
 Flyback

2. Features

Low drain-source on-resistance: $R_{DS(ON)} = 80\text{m}\Omega$ (typ.)
 Easy to control Gate switching
 Enhancement mode: $V_{th} = 2$ to 4 V

Table 1 Key Performance Parameters

Parameter	Value	Unit
V_{DS} @ $T_{j,max}$	1200	V
$R_{DS(on),max}$	100	m Ω
$Q_{g,typ}$	58	nC
$I_{D,pulse}$	94	A

3. Packaging and Internal Circuit

Part Name	Package	Marking
RTQ120N080G2	TO-247-4L	RTQ120N080G2
RTW120N080G2	TO-247-3L	RTW120N080G2
RTG120N080G2	TO-263-7L	RTG120N080G2

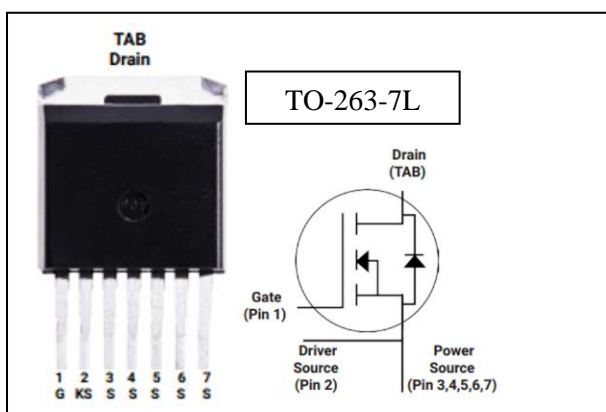
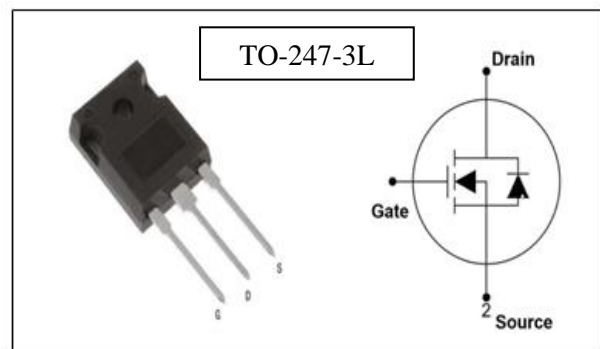
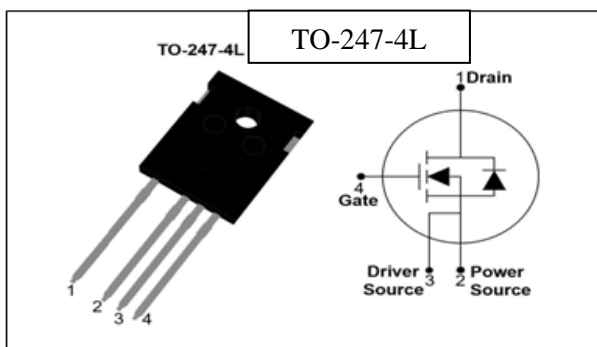

RTQ120N080G2, RTW120N080G2, RTG120N080G2

1 Maximum ratings

at $T_j = 25^\circ\text{C}$, unless otherwise specified

Table 2 Maximum ratings

Parameter	Symbol	Values			Unit	Note / Test Condition
		Min.	Typ.	Max.		
Continuous drain current ¹⁾	I_D	-	-	35	A	TC=25°C
		-	-	26	A	TC=100°C
Avalanche energy, single pulse	E_{AS}	-	-	200	mJ	Tc=25°C, VDD=50V, L=1mH, RG=25Ω
Gate source voltage (static)	V_{GS}	-5	-	20	V	static;
Power dissipation	P_{tot}	-	-	188	W	TC=25°C
Derating factor above 25°C		-	-	1.9	W/°C	
Storage temperature	T_{stg}	-55	-	175	°C	
Operating junction temperature	T_j	-55	-	175	°C	
Soldering Temperature Distance of 1.6mm from case for 10s	T_L			300	°C	
Transconductance	GFS	-	8.33	-	S	VDS=20V IDS=20A
		-	7.14	-		VDS=20V IDS=20A, Tj=150°C

¹⁾Limited by $T_{j,max}$. Maximum Duty Cycle D = 0.50

²⁾Pulse width t_p limited by $T_{j,max}$

³⁾Identical low side and high side switch with identical R_G

2 Thermal characteristics

Table 3 Thermal characteristics

TO247

Parameter	Symbol	Values			Unit	Note / Test Condition
		Min.	Typ.	Max.		
Thermal resistance, junction - case	R_{thJC}	-	0.65	0.8	°C/W	-
Thermal resistance, junction - ambient	R_{thJA}	-	-	40	°C/W	device on PCB, minimal footprint

TO263-7L

Parameter	Symbol	Values			Unit	Note / Test Condition
		Min.	Typ.	Max.		
Thermal resistance, junction - case	R_{thJC}	-	-	1.0	°C/W	-
Thermal resistance, junction - ambient	R_{thJA}	-	-	62	°C/W	device on PCB, minimal footprint

3 Electrical characteristics

 at $T_j=25^\circ\text{C}$, unless otherwise specified

Table 4 Static characteristics

Parameter	Symbol	Values			Unit	Note / Test Condition
		Min.	Typ.	Max.		
Drain-source breakdown voltage	$V_{(BR)DSS}$	1200	-	-	V	$V_{GS}=0V, I_D=1mA$
Gate threshold voltage	$V_{(GS)th}$	2.0	2.8	4.0	V	$V_{DS}=V_{GS}, I_D=10mA$
Zero gate voltage drain current	I_{DSS}	-	-	1	μA	$V_{DS}=1200V, V_{GS}=0V$
Gate-source leakage current	I_{GSS+}	-	-	100	nA	$V_{GS}=20V, V_{DS}=0V$
Gate-source leakage current	I_{GSS-}	-	-	-100	nA	$V_{GS}=-5V, V_{DS}=0V$
Drain-source on-state resistance	$R_{DS(on)}$	-	80	100	$m\Omega$	$V_{GS}=20V, I_D=20A, T_j=25^\circ\text{C}$
			93.1			$V_{GS}=20V, I_D=20A, T_j=150^\circ\text{C}$
Gate resistance (Intrinsic)	R_G	-	4.5	-	Ω	$f=1\text{MHz}$, open drain

Table 5 Dynamic characteristics

Parameter	Symbol	Values			Unit	Note / Test Condition
		Min.	Typ.	Max.		
Input capacitance	C_{iss}	-	1377	-	pF	$V_{GS}=0V, V_{DS}=1000V, f=200\text{KHz}$
Output capacitance	C_{oss}	-	62	-	pF	$V_{GS}=0V, V_{DS}=1000V, f=200\text{KHz}$
Reverse transfer capacitance	C_{rss}	-	4	-	pF	$V_{GS}=0V, V_{DS}=1000V, f=200\text{KHz}$
Turn-on delay time	$t_{d(on)}$	-	10	-	ns	$V_{DD}=800V, V_{GS}=20V,$ $I_D=20A, R_G=0\Omega;$ $T_j=25^\circ\text{C}$
Rise time	t_r	-	6	-	ns	
Turn-off delay time	$t_{d(off)}$	-	16	-	ns	
Fall time	t_f	-	10	-	ns	
Turn-on Switching Energy	E_{on}		748.8		μJ	
Turn-off Switching Energy	E_{off}		31.2		μJ	

Table 6 Gate charge characteristics

Parameter	Symbol	Values			Unit	Note / Test Condition
		Min.	Typ.	Max.		
Gate to source charge	Q_{gs}	-	18	-	nC	$V_{DD}=800V, I_D=20A, V_{GS}=20V$
Gate to drain charge	Q_{gd}	-	17	-	nC	$V_{DD}=800V, I_D=20A, V_{GS}=20V$
Gate charge total	Q_g	-	58	-	nC	$V_{DD}=800V, I_D=20A, V_{GS}=20V$

RTQ120N080G2, RTW120N080G2, RTG120N080G2

Table 7 Reverse diode characteristics

Parameter	Symbol	Values			Unit	Note / Test Condition
		Min.	Typ.	Max.		
Continuous Source Current	I_{SD}	-	-	35	A	
Diode forward voltage	V_{SD}	-	3.8	-	V	$I_S = 10A, V_{GS} = 0V, T_J = 25^\circ C$
Reverse recovery time	t_{rr}	-	57	-	ns	$V_{DD} = 800V, I_D = 20A, +V_{GS} = +15V, -V_{GS} = -4V$ $L_{Load} = 500\mu H, R_g = 0\Omega, T_J = 25^\circ C$
Reverse recovery charge	Q_{rr}	-	195	-	nC	
Peak reverse recovery current	I_{rrm}	-	6.84	-	A	

4 Electrical characteristics diagram

Diagram 1: Typ. output characteristics

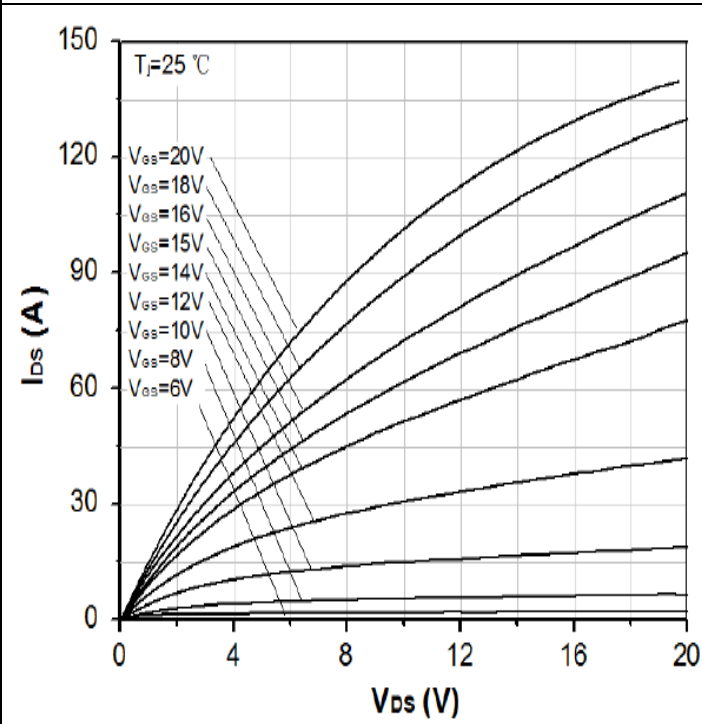

$I_D=f(V_{DS}); T_J=25\text{ }^\circ\text{C};$ parameter: V_{GS}

Diagram 2: Typ. output characteristics

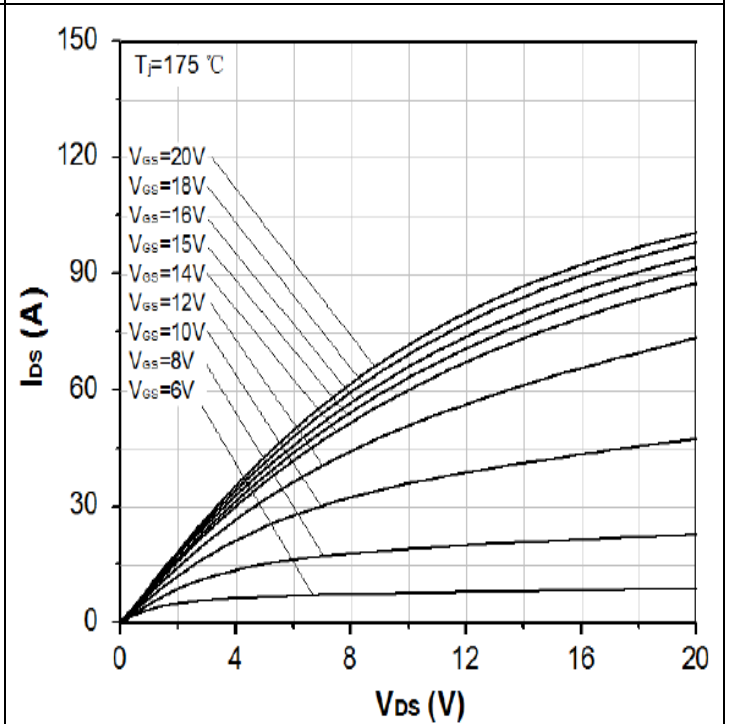

$I_D=f(V_{DS}); T_J=175\text{ }^\circ\text{C};$ parameter: V_{GS}

Diagram 3: Typ. transfer characteristics

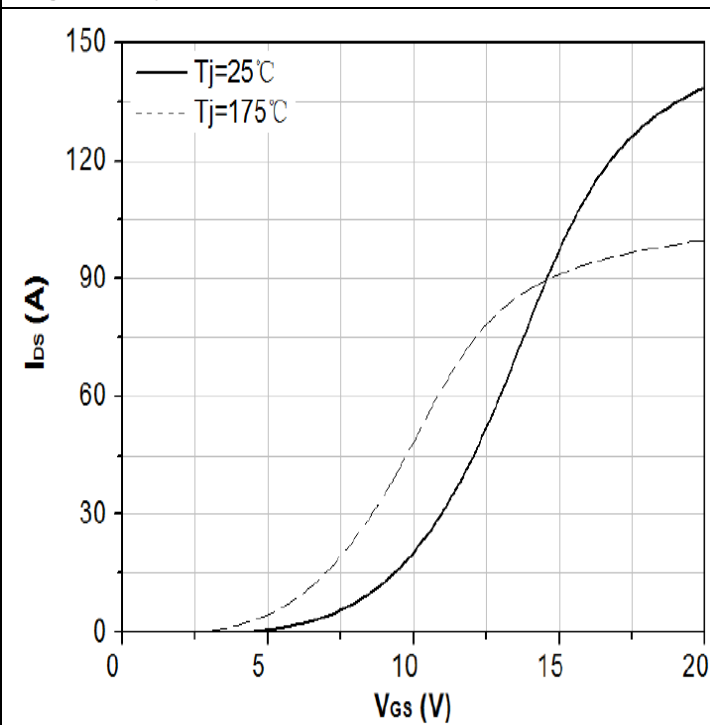

$I_D=f(V_{GS}); V_{DS}=20\text{V};$ parameter: T_J

Diagram 4: Typ. gate charge

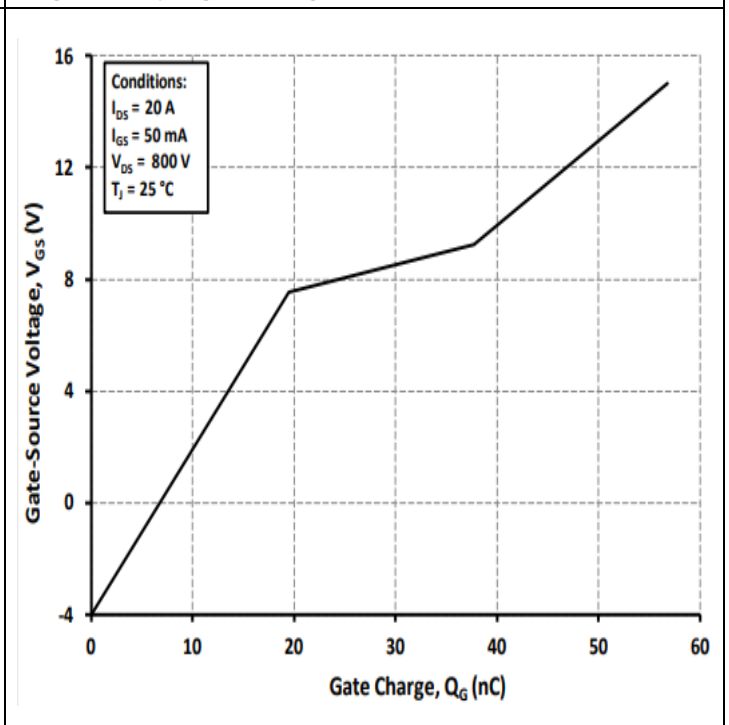

$V_{GS}=f(Q_{gate}); I_D=20\text{A}; V_{DS}=800\text{V};$ turn-on pulse

RTQ120N080G2, RTW120N080G2, RTG120N080G2

Diagram 5: Typical gate-source threshold voltage as a function of junction temperature

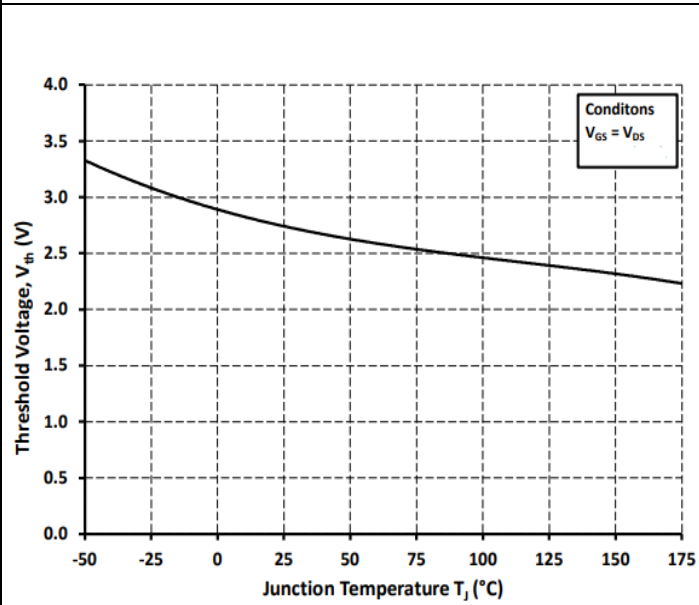

$$V_{GS(th)} = f(T_j); I_{DS} = 10 \text{ mA}; V_{GS} = V_{DS}$$

Diagram 6: Typ. Capacitance as a function of drain-source voltage

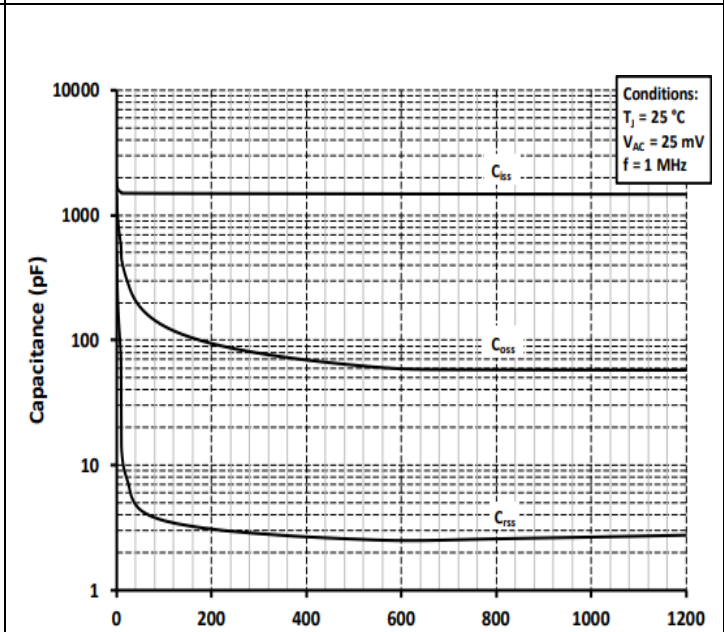

$$C = f(V_{DS}); V_{GS} = 0 \text{ V}; f = 1 \text{ MHz}$$

Diagram 7: Normalized on-resistance as a function of junction temperature

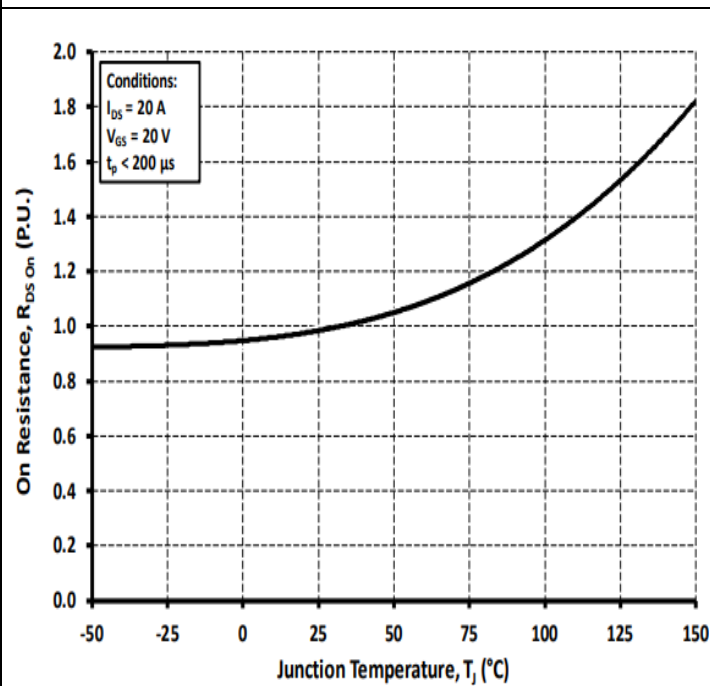

$$R_{DS(ON)} = f(T_j); I_{DS} = 20 \text{ A}$$

Diagram 8: Typical body diodes forward voltage as function of junction temperature

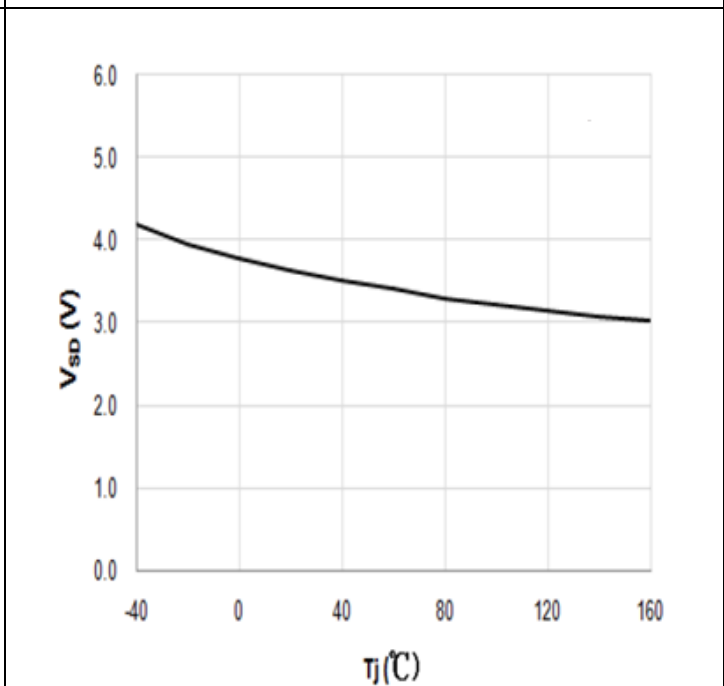

$$V_{SD} = f(T_j); V_{GS} = 0 \text{ V}; I_{SD} = 10 \text{ A}$$

RTQ120N080G2, RTW120N080G2, RTG120N080G2

Diagram 9: Typical body diodes forward current as function of forward voltage, V_{GS} as parameter

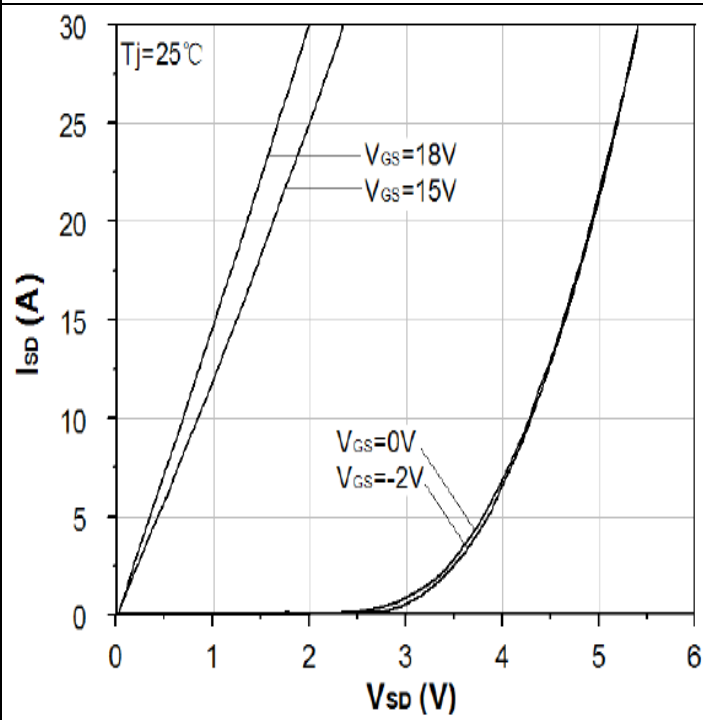

$$I_{SD} = f(V_{SD}); T_j = 25^\circ\text{C}$$

Diagram 10: Typical body diodes forward current as function of forward voltage, V_{GS} as parameter

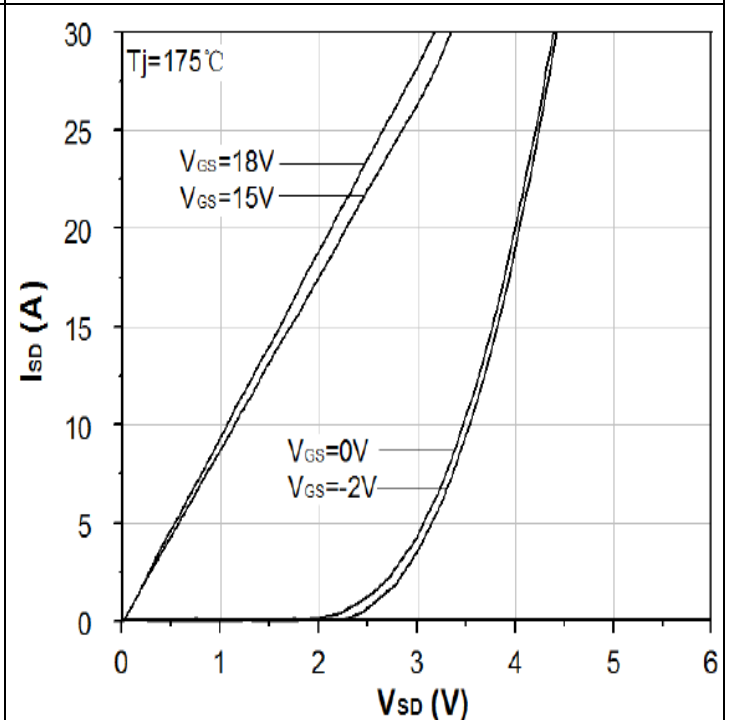

$$I_{SD} = f(V_{SD}); T_j = 175^\circ\text{C}$$

Diagram 11: Safe operating area(SOA)

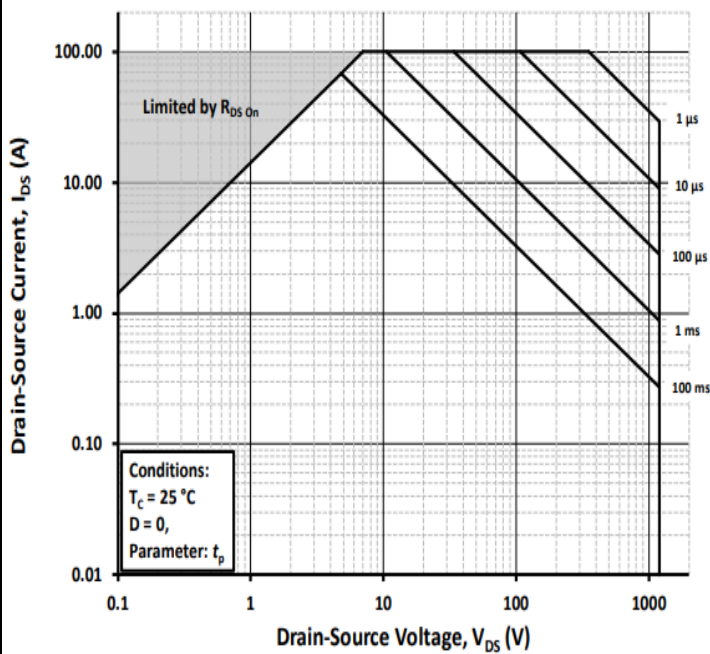

$$V_{GS} = 0/18\text{V}; T_c = 25^\circ\text{C}; T_j < 175^\circ\text{C}$$

Diagram 12: Power dissipation as a function of case temperature limited by bond wire

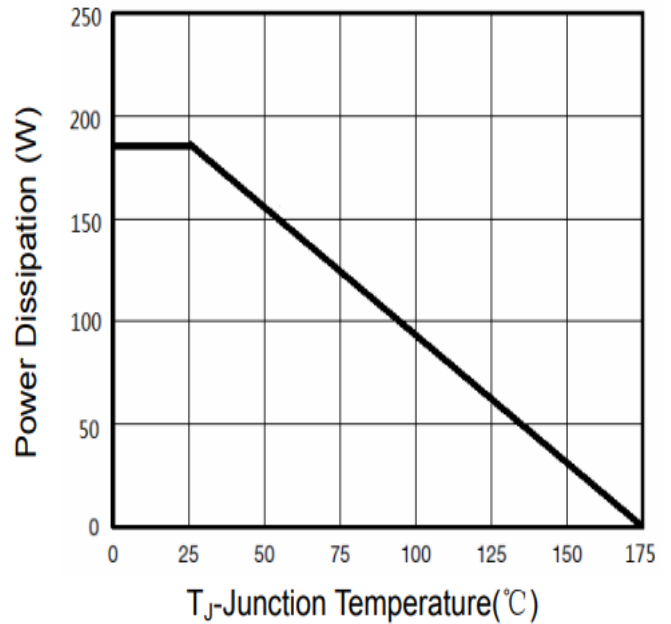

$$P_{tot} = f(T_c)$$

RTQ120N080G2, RTW120N080G2, RTG120N080G2

Diagram 13: Maximum DC drain to source current as a function of case temperature limited by bond wire

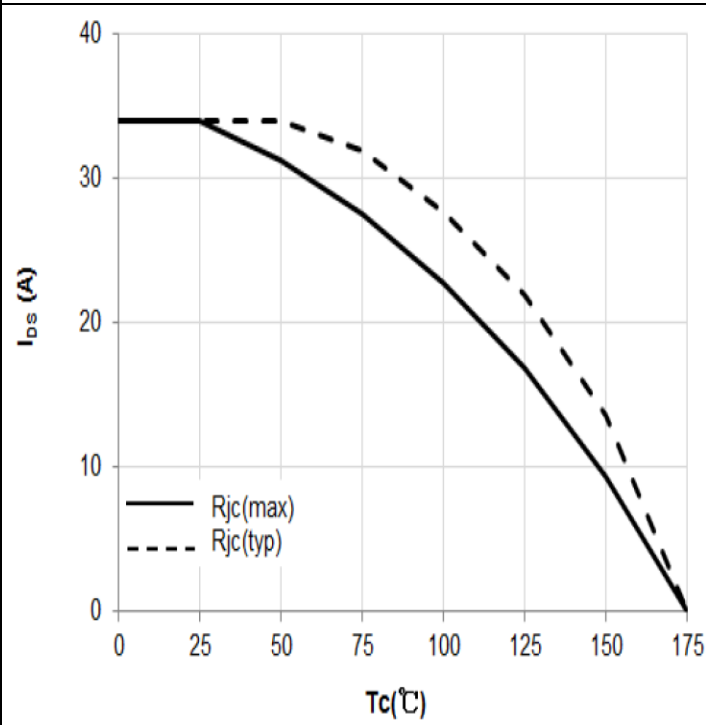

$I_{DS} = f(T_C)$

Diagram 14: Maximum source to drain current as a function of case temperature limited by bond wire

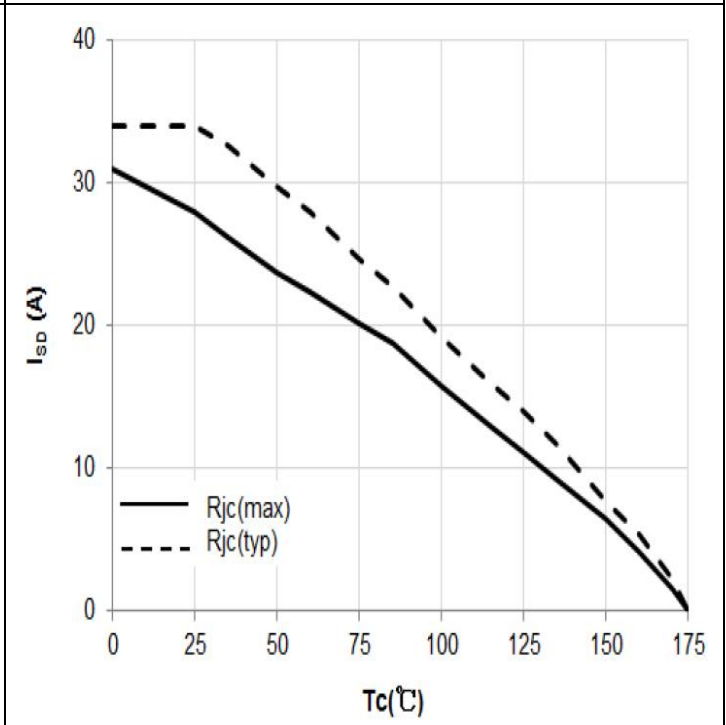

$I_{SD} = f(T_C), V_{GS} = 0V$

Diagram 15: Max. transient thermal resistance(MOSFET/diodes)

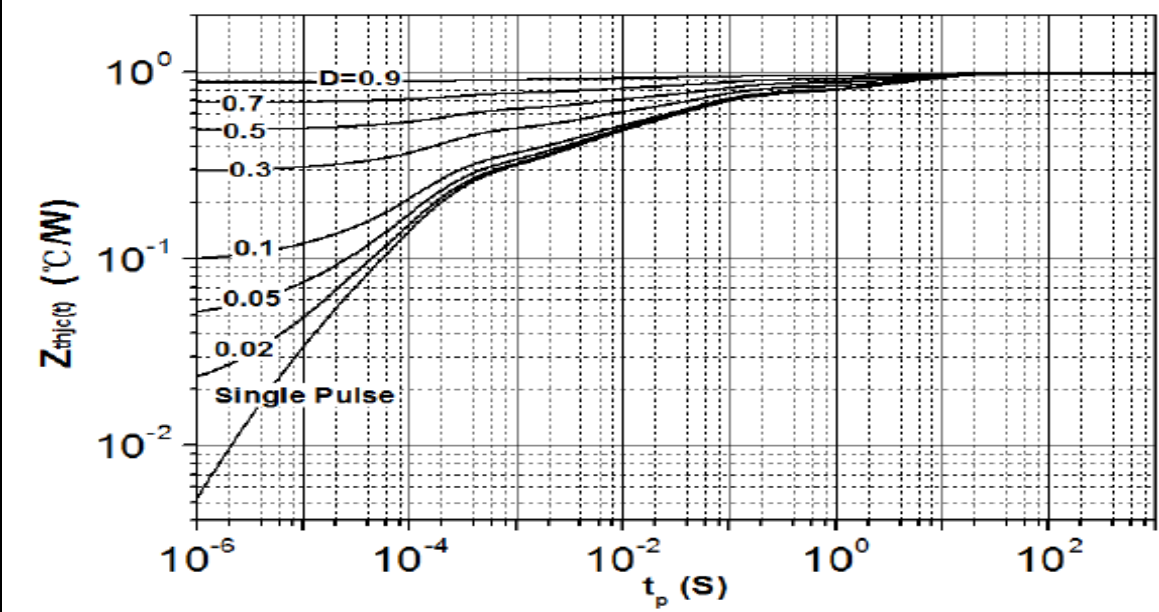

$Z_{th(j-c, max)} = f(t_p), \text{parameter } D = t_p / T$

5 Test Circuits

Table 8 Diode characteristics

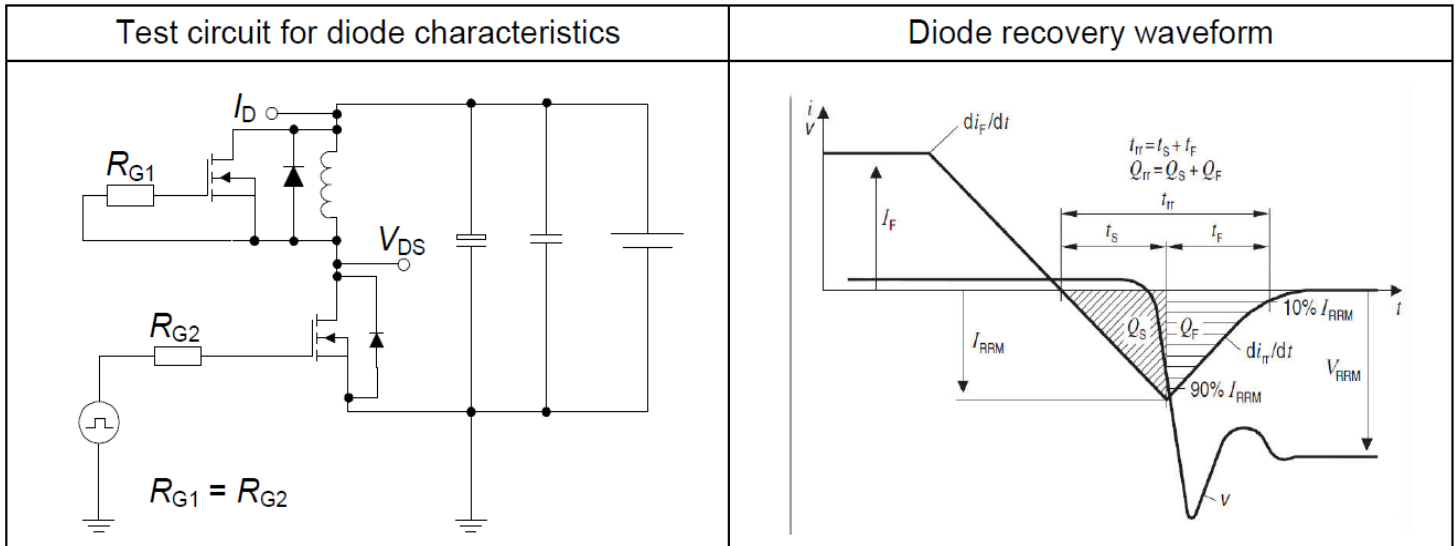
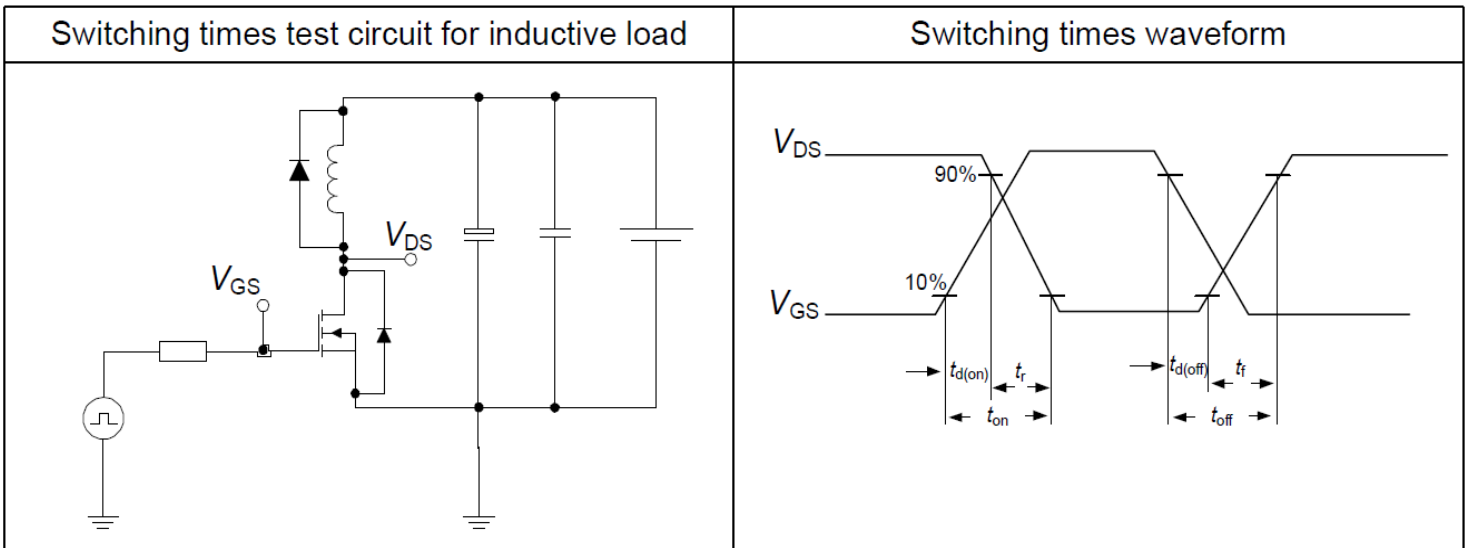

Table 9 Switching times



RTQ120N080G2, RTW120N080G2, RTG120N080G2

6 Package Outlines

TO-247-4L

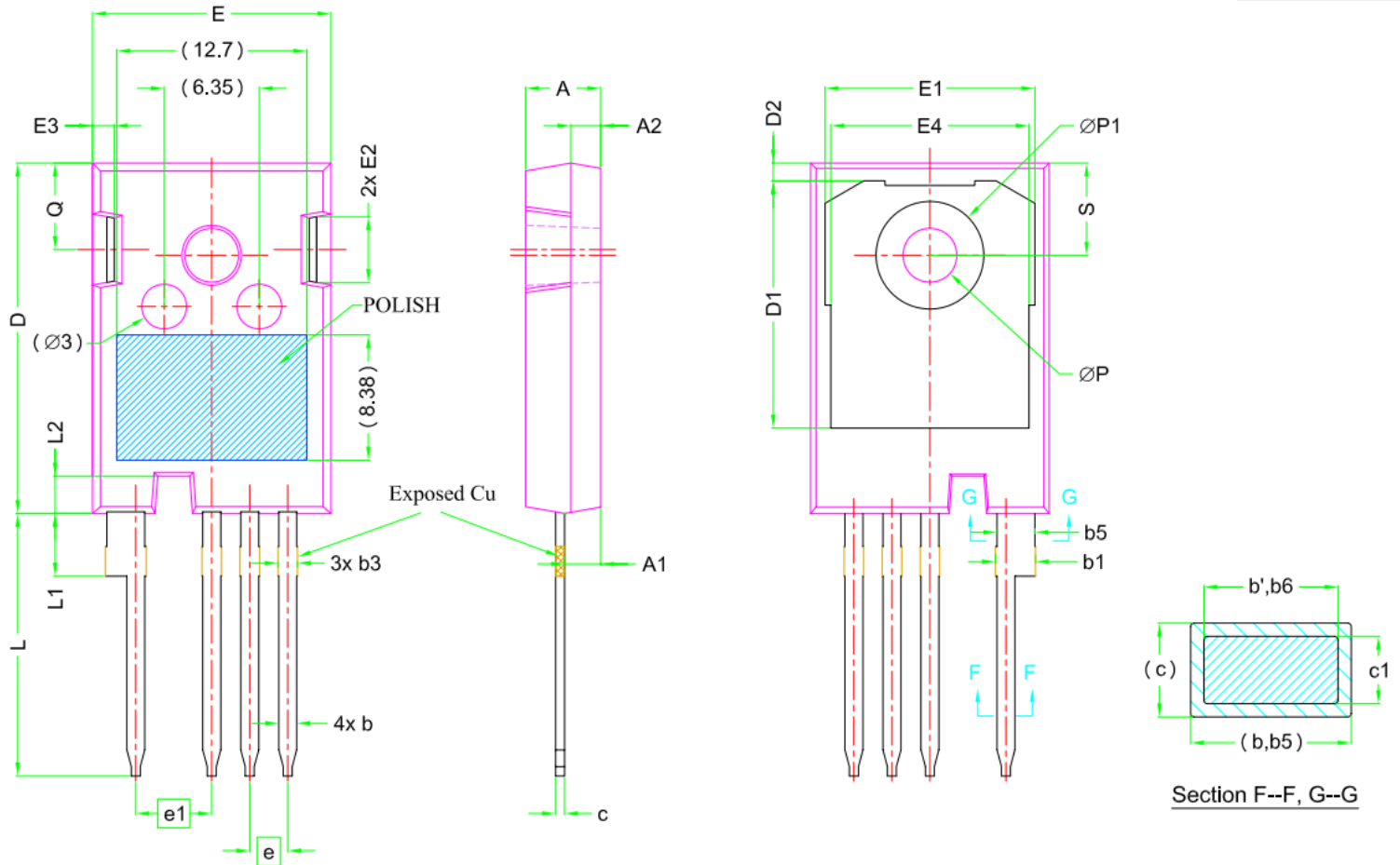

SYMBOL	DIMENSIONS		
	MIN.	NOM.	MAX.
A	4.83	5.02	5.21
A1	2.29	2.41	2.54
A2	1.91	2.00	2.16
b'	1.07	1.20	1.28
b	1.07	1.20	1.33
b1	2.39	2.67	2.94
b3	1.07	1.30	1.60
b5	2.39	2.53	2.69
b6	2.39	2.53	2.64
c	0.55	0.60	0.68
c1	0.55	0.60	0.65
D	23.30	23.45	23.60
D1	16.25	16.55	17.65
D2	0.95	1.19	1.25
E	15.75	15.94	16.13
E1	13.10	14.02	14.15
E2	3.68	4.40	5.10
E3	1.00	1.45	1.90
E4	12.38	13.26	13.43
e	2.54 BSC		
e1	5.08 BSC		
L	17.31	17.57	17.82
L1	3.97	4.19	4.37
L2	2.35	2.50	2.65
∅P	3.51	3.61	3.65
∅P1	7.19 REF.		
Q	5.49	5.79	6.00
S	6.04	6.17	6.30

RTQ120N080G2, RTW120N080G2, RTG120N080G2

TO-247-3L

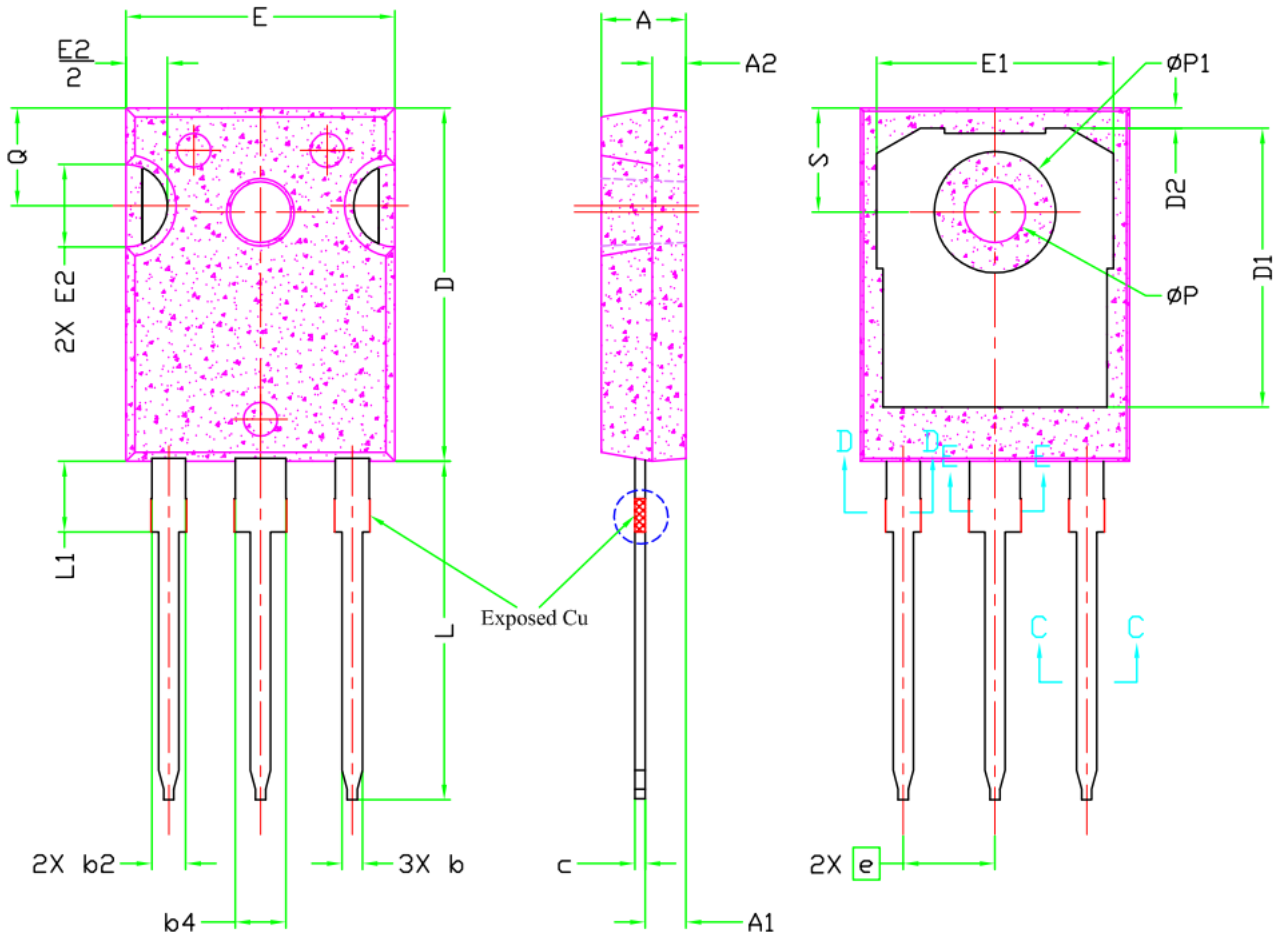

SYMBOL	DIMENSIONS			NOTES
	MIN.	NOM.	MAX.	
A	4.83	5.02	5.21	
A1	2.29	2.41	2.55	
A2	1.50	2.00	2.49	
b	1.12	1.20	1.33	
b1	1.12	1.20	1.28	
b2	1.91	2.00	2.39	6
b3	1.91	2.00	2.34	
b4	2.87	3.00	3.22	6, 8
b5	2.87	3.00	3.18	
c	0.55	0.60	0.69	6
c1	0.55	0.60	0.65	
D	20.80	20.95	21.10	4
D1	16.25	16.55	17.65	5
D2	0.51	1.19	1.35	
E	15.75	15.94	16.13	4
E1	13.46	14.02	14.16	5
E2	4.32	4.91	5.49	3
e	5.44BSC			
L	19.81	20.07	20.32	
L1	4.10	4.19	4.40	6
$\varnothing P$	3.56	3.61	3.65	7
$\varnothing P1$	7.19REF.			
Q	5.39	5.79	6.20	
S	6.04	6.17	6.30	

RTQ120N080G2, RTW120N080G2, RTG120N080G2

TO-263-7L

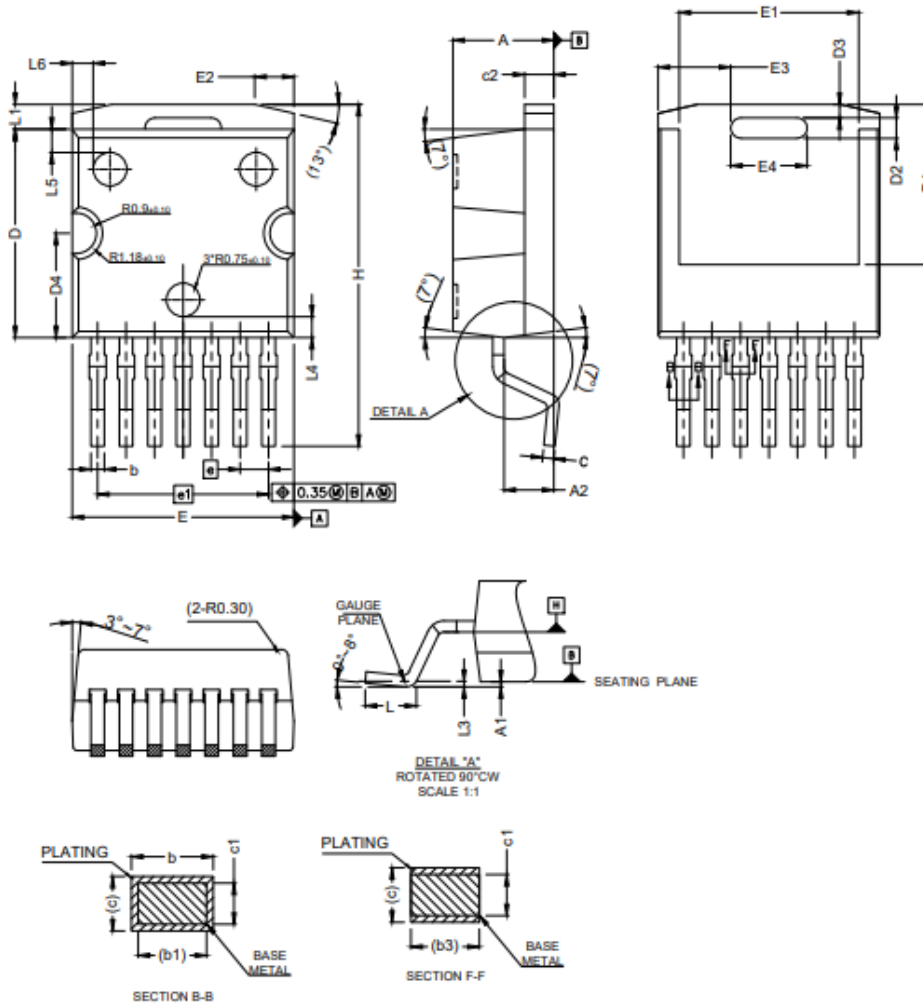

SYMBOL	MIN	MAX	SYMBOL	MIN	MAX
A	4.30	4.70	L	1.78	2.79
A1	-	0.25	L1	-	1.60
A2	2.02	2.42	L3	0.25BSC	
b	0.50	0.70	L4	0.93BSC	
b1	0.50	0.65	L5	1.04BSC	
b3	0.60	0.75	L6	0.93BSC	
c	0.45	0.60	H	14.61	15.88
c1	0.45	0.55			
c2	1.25	1.40			
D	9.10	9.50			
D1	6.86	7.42			
D2	0.72	1.12			
D3	0.40	0.80			
D4	4.45	4.85			
E	9.68	10.08			
E1	7.70	8.30			
E2	1.55	1.95			
E3	3.04	3.44			
E4	3.21	3.61			
e	1.27 BSC				
e1	7.62 BSC				

RTQ120N080G2, RTW120N080G2, RTG120N080G2

Revision History

Revision	Date	Subjects (major changes since last revision)
1.0	2022-05-27	Preliminary version